

# SPECIFICATIONS FOR LCD MODULE

MODEL NO.  
BC2004AYPGEH20c3\$  
VER.01



FOR MESSRS:

---

ON DATE OF:

---

APPROVED BY:

---

**BOLYMIN, INC.**

5F, No. 38, Keya Rd., Daya Dist., Central Taiwan Science Park, Taichung City, 42881, Taiwan.

Web Site:<http://www.bolymin.com.tw> TEL:+886-4-25658689 FAX:+886-4-25658698

### History of Version

Version	Contents	Date	Note
01	NEW VERSION	2018/01/24	SPEC.

## CONTENTS

1. Numbering System
2. Handling Precaution
3. General Specification
4. Absolute Maximum Rating
5. Electrical Characteristics
6. Optical Characteristics
7. Interface Pin Function
8. Power supply for LCD Module and LCD operating voltage adjustment
9. Backlight information
10. Quality Assurance
11. Reliability
12. Appendix (Drawing , PCF2116CU controller data)
  - 12-1 Drawing
  - 12-2 PCF2116CU controller data
    - 12-2.1 Function description
    - 12-2.2 C.G ROM table. table 2
    - 12-2.3 Instruction table
    - 12-2.4 Timing characteristics
    - 12-2.5 Initializing soft ware of LCM

## 1. Numbering System

<u>B</u>	<u>C</u>	<u>2004</u>	<u>A</u>	<u>Y</u>	<u>P</u>	<u>G</u>	<u>E</u>	<u>H</u>	<u>20c3\$</u>
0	1	2	3	4	5	6	7	8	9

<b>0</b>	Brand	Bolymin							
<b>1</b>	Module Type	C= character type G= graphic type P= TAB/TCP type				O= COG type F= COF type L=PLED/OLED			
<b>2</b>	Format	2002=20 characters, 2 lines 12232= 122 x 32 dots							
<b>3</b>	Version No.	A type							
<b>4</b>	LCD Color	G=STN/gray Y=STN/yellow-green PLED/yellow-green C=color STN,OLED/RGB				B=STN/blue,OLED/blue F=FSTN T=TN			
<b>5</b>	LCD Type	R=positive/reflective P=positive/transflective				M=positive/transmissive N=negative/transmissive			
<b>6</b>	Backlight type/color	L=LED array/ yellow-green H=LED edge/white R=LED array/red G=LED edge/yellow-green F=RGB array I=RGB edge Q=LED edge/red N=No backlight				D=LED edge/blue E=EL/white B=EL/blue C=CCFL/white Y=LED Bottom/yellow O=LED array/orange K=LED edge/green A=LED edge/amber			
<b>7</b>	CGRAM Font (applied only on character type)	J=English/Japanese Font E=English/European Font G=Chinese(simple) F=Chinese(traditional)				C=English/Cyrillic Font H=English/Hebrew Font A=English/Arabic Font			
<b>8</b>	View Angle/ Operating Temperature	B=Bottom/Normal Temperature H=Bottom/Wide Temperature U=Bottom/Ultra wide Temperature				T=Top/Normal Temperature W=Top/Wide Temperature C=9H/Normal Temperature E=Top/ultra wide temperature			
<b>9</b>	Special Code	3=3.3 volt logic power supply n=negative voltage for LCD c=cable/connector xxx=to be assigned on datasheet 20c=I2C interface				t=temperature compensation for LCD p=touch panel \$=RoHS			

## 2. Handling Precaution

### 2.1 Precaution in use of LCD Module

- 2.1.1. LCD panel is made of glass. Avoid excessive mechanical shock or applying strong pressure and/or sharp tools on the surface of display area.
- 2.1.2. The polarizer placed on the display surface is easily scratched and damaged. Extreme care should be taken when handling it. To clean dust or dirt off the display surface, wipe gently with cotton, or other soft material soaked with isopropyl alcohol, ethyl alcohol, do not use water, ketone or aromatics to clear display surface, and never scrub it hard.
- 2.1.3. Keep LCD panels away from direct sunlight. The storage environment should be dust-free, clean, dry, temperature is  $25^{\circ}\text{C} \pm 10^{\circ}\text{C}$  and the humidity is below 55% RH.
- 2.1.4. Do not input any signal before power is turned on.
- 2.1.5. Avoid pressing on the metal bezel, otherwise the elastomer connector could be deformed and lose contact, resulting in missing pixels and also cause rainbow on the display.
- 2.1.6. It's important to control soldering temperature and time. RoHS compliant materials might need higher temperature and time, but try to keep temperature under  $350^{\circ}\text{C}$  and time in 3-5 sec.
- 2.1.7. EL is manufactured from the organic film, and is easily affected by temperature, humidity and other environmental impact. Long time storage might cause low quality of the case. Therefore, please start production in 3 months after reception of the LCM. If in any case, long time storage over 3 months is necessary, please keep EL in vacuum package or at least in humidity  $< 35\%$  RH, and temperature  $25^{\circ}\text{C} \pm 10^{\circ}\text{C}$ .  
Note: 2.1.7. is applied to EL backlight only.

### 2.2 Static Electricity Precautions:

- 2.2.1. The LCD module contains a C-MOS LSI. People who operate the LCM should wear ESD protection equipment to prevent ESD hurt on products.
- 2.2.2. Do not touch any of the conductive parts such as the LSI pads; the copper leads on the PCB and the interface terminals with any parts of the human body.
- 2.2.3. Do not touch the connection terminals of the display with bare hand; it will cause disconnection or defective insulation of terminals.
- 2.2.4. The modules should be kept in anti-static bags or trays for storage.
- 2.2.5. Only properly grounded soldering irons should be used.
- 2.2.6. If an electric screwdriver is used, it should be grounded and shielded to prevent sparks.
- 2.2.7. The normal static prevention measures should be observed for work clothes and working benches.
- 2.2.8. Since dry air(almost low RH) is inductive to static, a humidity of 50-60% RH is recommended in assembly line.

### 2.3 Operation Precautions:

- 2.3.1. DC voltage applied on LCM causes electrochemical reactions, which will deteriorate the display over time. The applied pulse waveform should be a symmetric waveform such that no DC component remains. Be sure to use the specified operating voltage.
- 2.3.2. LCD driving voltage should be kept within specified range; excess voltage will shorten display life, while less voltage may not turn on LCM.
- 2.3.3. LCM response time will be extremely delayed in low operating temperature(such as  $-20^{\circ}\text{C}$ ) than in room operating temperature. Therefore, higher LCD driving voltage is required in low operating temperature; On the other hand, in high operating temperature (such as  $+70^{\circ}\text{C}$ ) LCD shows dark background color, therefore lower LCD driving voltage is required. Be sure to use the specified LCD driving voltage in different operating temperature.

## 2.4 Safety:

- 2.4.1 If the LCD panel breaks, be careful not to get the liquid crystal to touch your skin.  
If the liquid crystal touches your skin or clothes, please wash it off immediately by using soap and water.

## 2.5 WARRANTY POLICY

**Bolymin .Will provide one-year warranty for the products only if under specification operating conditions.**

**If there are functional defects found during the period of warranty, the defective products would be replaced on a one-to-one basis.**

**Bolymin would not be responsible for any direct/indirect liabilities consequential to any parties.**

## 2.6 MTBF

- 2.6.1 .By specific test condition, MTBF based on 30°C normal operation temperature is 50,000hours.

### 2.6.2 Test Condition:

2.6.2.1 Supply Voltage for LCM: Typical Vdd

2.6.2.2 CC (Constant Current) mode and typical current is applied for LED.

2.6.2.3 Run-Patterns: by Bolymin's test program that has defined patterns and cyclic period.

2.6.2.4 Humidity: 60%RH

### 2.6.3 Test Criteria:

Attenuation of average brightness:  $\leq 50\%$

Increasing of current consumption for LCM/Backlight:  $\leq 20\%$

Display function at room temperature: Normal

Appearance: Normal

### 3.General Specification

#### (1) Mechanical Dimension

Item	Dimension	Unit
Number of Characters	20characters x4 Lines	—
Module dimension ( L x W x H )	98.0 x 60.0 x 13.6 (Max)—LED B/L	mm
View area	77.0 x 25.2	mm
Active area	70.4 x 20.8	mm
Dot size	0.55 x 0.55	mm
Dot pitch	0.60 x 0.60	mm
Character size ( L x W )	2.95 x 4.75	mm
Character pitch ( L x W )	3.55 x 5.35	mm

#### (2) Controller IC: PCF2116CU (or Equivalent) controller

### 4. Absolute Maximum Rating

#### 4.1 Electrical Absolute Maximum Ratings

(V<sub>SS</sub>=0V, T<sub>a</sub>=25°C)

Item	Symbol	Min	Max	Unit
Supply Voltage (Logic)	V <sub>DD</sub>	-0.5	8	V
LCD supply voltage	V <sub>LCD</sub>	V <sub>DD</sub> -11	V <sub>DD</sub>	V
Input Voltage	V <sub>I</sub>	V <sub>SS</sub> -0.5	V <sub>DD</sub> +0.5	V

#### 4.2 Environmental Absolute Maximum Ratings

Item	Symbol	Min	Max	Unit	Note
Operating Temperature	TOP	-20	70	°C	(1)
Storage Temperature	TST	-30	80	°C	(1)

Note (1)

- (a) 90 %RH Max. ( $T_a \leq 40$  °C).
- (b) Wet-bulb temperature should be 39 °C Max. ( $T_a > 40$  °C).
- (c) No condensation.

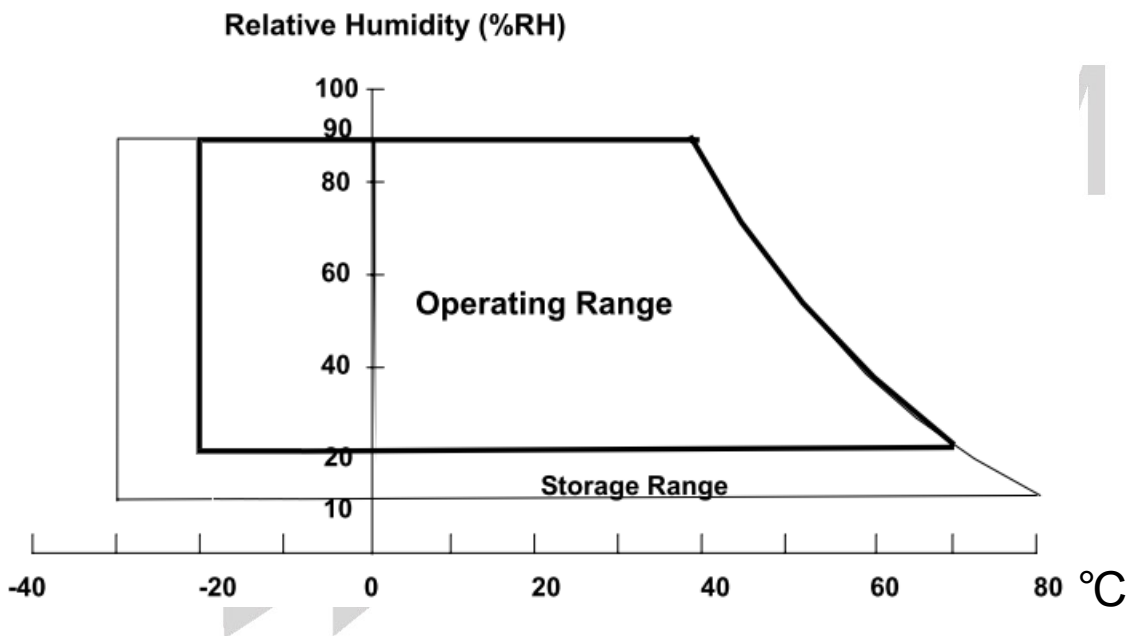



## 5. Electrical Characteristics

Item	Symbol	Condition	Min	Typ	Max	Unit
Supply Voltage For Logic	$V_{DD} - V_{SS}$	—	2.5	3.3	3.6	V
Supply Voltage For LCD * Wide Temp、Type	$V_{DD} - V_0$	$T_a = 25^{\circ}\text{C}$	4.0	-	4.6	V
Input High Volt.	$V_{IH}$	—	$0.7 V_{DD}$	—	$V_{DD}$	V
Input Low Volt.	$V_{IL}$	—	—	—	$0.3 V_{DD}$	V
Supply Current (without backlight)	$I_{DD}$	$V_{DD} = 3.3\text{V}$	—	1.6	—	mA
LCM Surface Luminance $T_a = 25^{\circ}\text{C}$	L	$I_{LED} = 45\text{mA}$ Display all OFF	1	2	—	$\text{cd/m}^2$

※Optimum LCD driving voltage value, referring to above mentioned range, is changed due to different batch of LCD glass.

BOLYMIN

## 6. Optical Characteristics

a. STN

( $T_a=25^\circ\text{C}$ )

Item	Symbol	Min.	Typ.	Max.	Unit
View Angle (CR $\geq$ 2)	$\theta_F$	-	30	-	deg
	$\theta_B$	-	35	-	deg
	$\varphi_L$	-	38	-	deg
	$\varphi_R$	-	40	-	deg
Contrast Ratio	CR	2	3	-	-
Response Time 25 $^\circ\text{C}$	T rise	-	200	350	ms
	T fall	-	200	400	ms

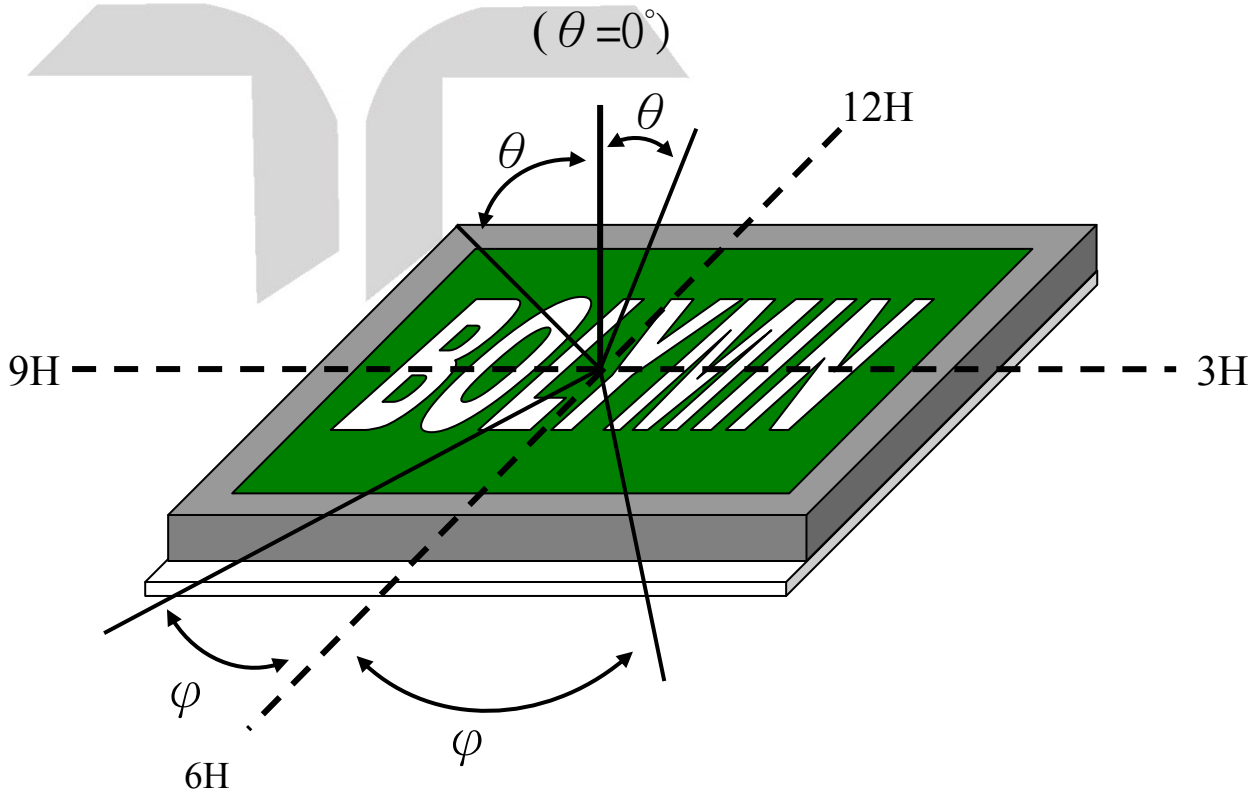

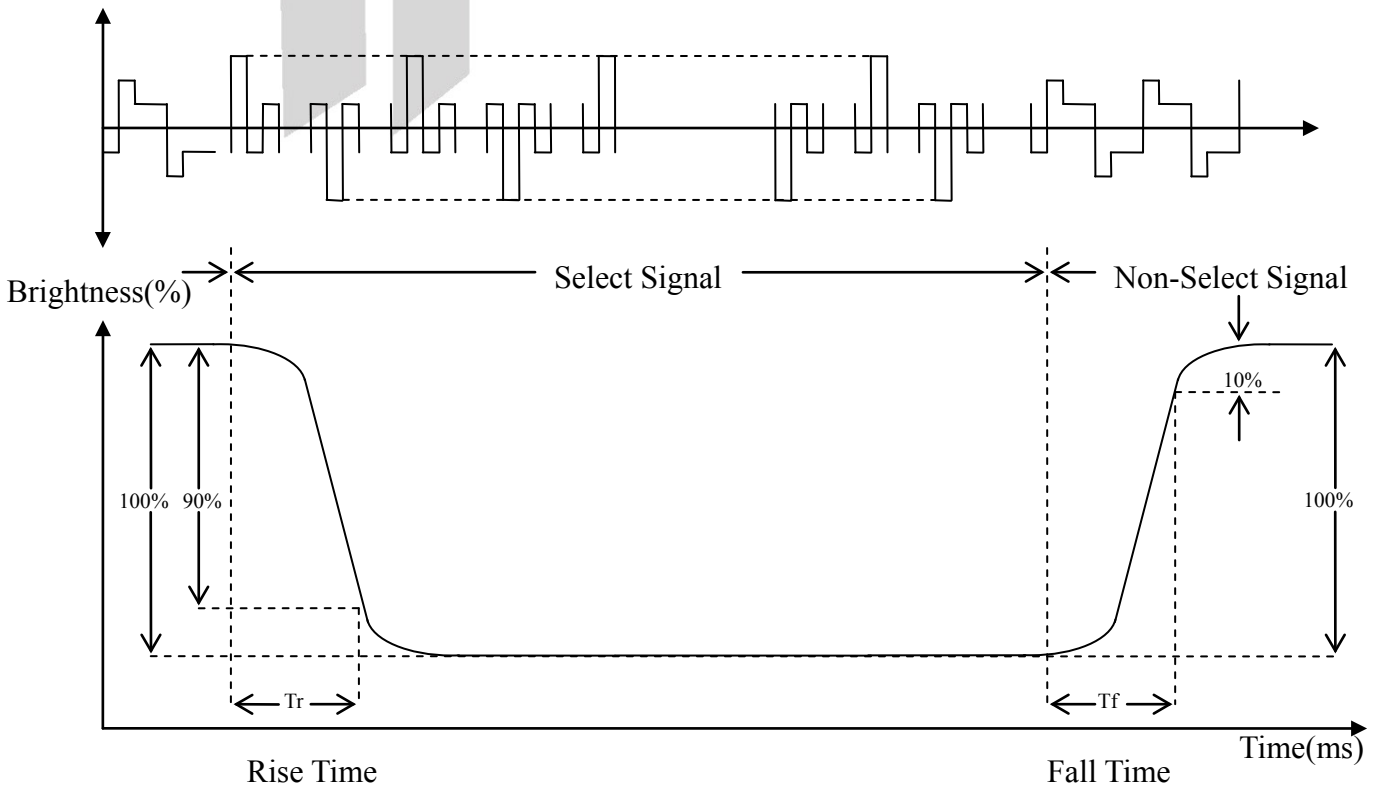
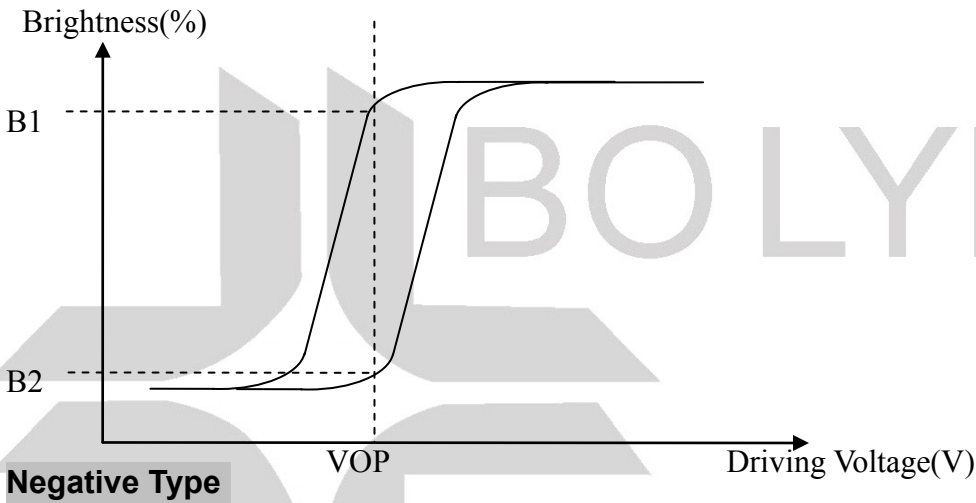
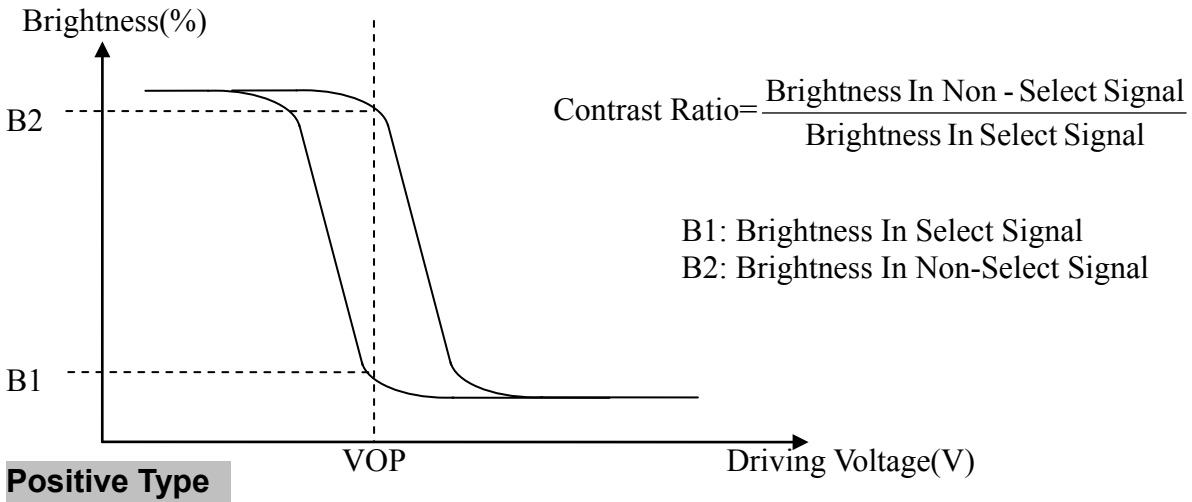

## 7. Interface Pin Function

Pin No.	Symbol	Level	Description
1	Vdd	3.3V	Supply voltage
2	SCL	H/L	Input for the I <sup>2</sup> C-bus clock signal.
3	SDA	H/L	Input/output for the I <sup>2</sup> C-bus data line.
4	Vss	Gnd	Ground

## 8. Power supply for LCD Module and LCD operating voltage adjustment

Standard Type

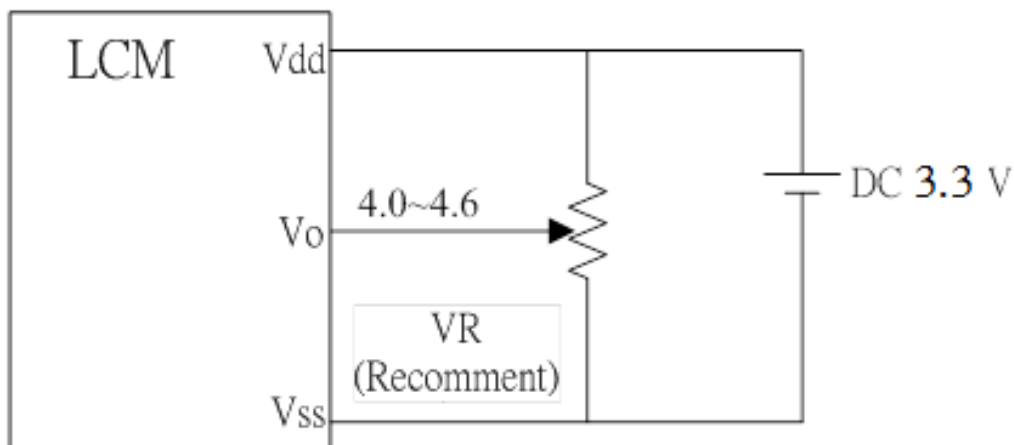

## 9. Backlight information

### 9.1 Specification

#### (1) LED edge /yellow-green

Parameter	Symbol	Min	Typ	Max	Unit	Test Condition
Supply Current	I <sub>LED</sub>	-	45	-	mA	V= 2.1V
Supply Voltage	V	1.9	2.1	2.3	V	I <sub>LED</sub> =45 mA
Reverse Voltage	V <sub>R</sub>	-	-	5	V	-
Wave Length	$\lambda$ p	465	-	475	nm	I <sub>LED</sub> =45mA
Color	yellow-green					

### 9.2 Backlight driving methods

LED B/L drive from K (V<sub>SS</sub>) A (V<sub>DD</sub>)

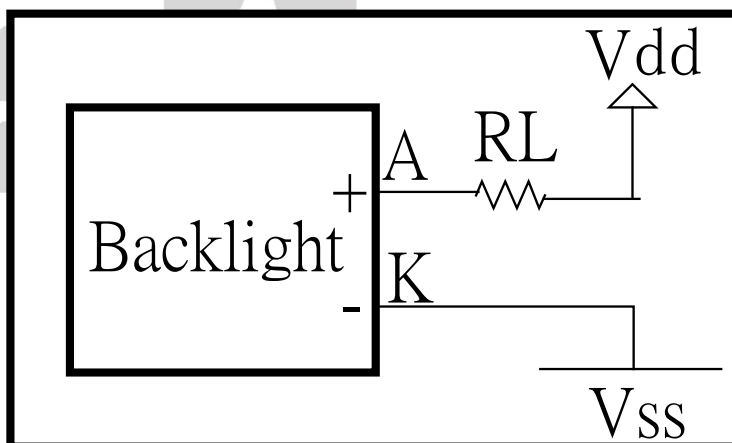

## 10. Quality Assurance

### 10.1 Inspection conditions

1. The LCD shall be inspected under 20~40W white fluorescent light.
2. Checking Direction shall be in the 40 degree from perpendicular line of specimen surface.
3. Checker shall see over 30 cm.
4. Inspect about 5 seconds for each side.
5. Defect that is located at outside of VA and doesn't affect function is ignored.

### 10.2 Inspection Parameters

NO.	Parameter	Criteria				
1	Black or White spots (Particle)	Zone		Acceptable Number	Class Of Defects	Acceptable Level
		Dimension				
		$D \leq 0.10$		Disregard	Minor	2.5
		$0.10 < D \leq 0.2$		4		
		$0.2 < D \leq 0.3$		2		
$0.3 < D$		0				
$D = (\text{Long} + \text{Short}) / 2$ Total defects should not exceed 5/module Defect that is located at outside of AA and doesn't affect function is ignored.						
2	Scratch, Substances	Zone		Acceptable Number	Class Of Defects	Acceptable Level
		X(mm)	Y(mm)			
		—	$0.05 \geq W$	Disregard	Minor	2.5
		$4.0 \geq L$	$0.05 \geq W$	4		
		$3.0 \geq L$	$0.1 \geq W$	2		
—	$0.1 < W$	0				
X: Length    Y: Width Total defects should not exceed 5/module Defect that is located at outside of AA and doesn't affect function is ignored.						

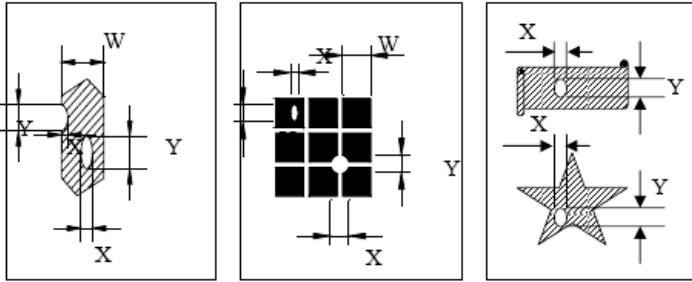
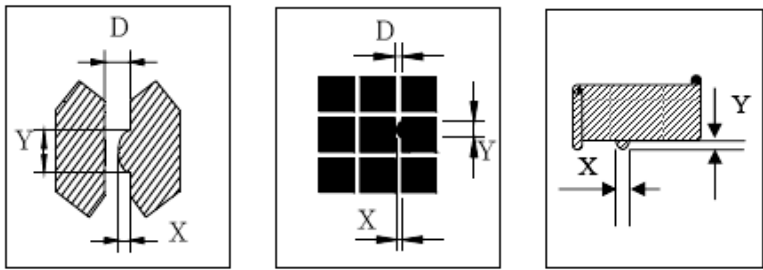
3	Air Bubbles ( between glass & polarizer)	<table border="1"> <thead> <tr> <th>Zone Dimension</th> <th>Acceptable Number</th> <th>Class Of Defects</th> <th>Acceptable Level</th> </tr> </thead> <tbody> <tr> <td><math>D \leq 0.2</math></td> <td>Disregard</td> <td rowspan="3">Minor</td> <td rowspan="3">2.5</td> </tr> <tr> <td><math>0.2 &lt; D \leq 0.5</math></td> <td>3</td> </tr> <tr> <td><math>0.5 &lt; D</math></td> <td>0</td> </tr> </tbody> </table>	Zone Dimension	Acceptable Number	Class Of Defects	Acceptable Level	$D \leq 0.2$	Disregard	Minor	2.5	$0.2 < D \leq 0.5$	3	$0.5 < D$	0														
Zone Dimension	Acceptable Number	Class Of Defects	Acceptable Level																									
$D \leq 0.2$	Disregard	Minor	2.5																									
$0.2 < D \leq 0.5$	3																											
$0.5 < D$	0																											
<p>Total defects shall not excess 3/module. Defect that is located at outside of AA and doesn't affect function is ignored. Bobble is sawn only under reflection light is disregarded.</p>																												
4	Displaying Pattern	<p>1. Incomplete or broken line is not allowed. 2. Pinholes</p> <table border="1"> <thead> <tr> <th>Dimension <math>\Phi</math>(mm)</th> <th>Criteria</th> <th>Class Of Defects</th> <th>Acceptable Level</th> </tr> </thead> <tbody> <tr> <td><math>\Phi &lt; 0.1</math></td> <td>Disregard</td> <td rowspan="4">Minor</td> <td rowspan="4">2.5</td> </tr> <tr> <td><math>0.1 &lt; \Phi \leq 0.2</math></td> <td>2</td> </tr> <tr> <td><math>0.2 &lt; \Phi \leq 0.25</math></td> <td>1</td> </tr> <tr> <td><math>0.25 &lt; \Phi</math></td> <td>0</td> </tr> </tbody> </table>  <p style="text-align: center;"><math>\phi = (X+Y)/2</math></p> <p>3. Deformation</p> <table border="1"> <thead> <tr> <th>Dimension <math>\Phi</math>(mm)</th> <th>Criteria</th> <th>Class Of Defects</th> <th>Acceptable Level</th> </tr> </thead> <tbody> <tr> <td><math>\Phi &lt; 0.15</math></td> <td>Disregard</td> <td rowspan="3">Minor</td> <td rowspan="3">2.5</td> </tr> <tr> <td><math>\Phi \leq 0.25</math> and <math>X \leq 1/2D</math></td> <td>3</td> </tr> <tr> <td><math>\Phi &gt; 0.25</math> and <math>X &gt; 1/2D</math></td> <td>0</td> </tr> </tbody> </table>  <p style="text-align: center;"><math>D</math> : 間距 <math>\phi = (X+Y)/2</math></p>	Dimension $\Phi$ (mm)	Criteria	Class Of Defects	Acceptable Level	$\Phi < 0.1$	Disregard	Minor	2.5	$0.1 < \Phi \leq 0.2$	2	$0.2 < \Phi \leq 0.25$	1	$0.25 < \Phi$	0	Dimension $\Phi$ (mm)	Criteria	Class Of Defects	Acceptable Level	$\Phi < 0.15$	Disregard	Minor	2.5	$\Phi \leq 0.25$ and $X \leq 1/2D$	3	$\Phi > 0.25$ and $X > 1/2D$	0
Dimension $\Phi$ (mm)	Criteria	Class Of Defects	Acceptable Level																									
$\Phi < 0.1$	Disregard	Minor	2.5																									
$0.1 < \Phi \leq 0.2$	2																											
$0.2 < \Phi \leq 0.25$	1																											
$0.25 < \Phi$	0																											
Dimension $\Phi$ (mm)	Criteria	Class Of Defects	Acceptable Level																									
$\Phi < 0.15$	Disregard	Minor	2.5																									
$\Phi \leq 0.25$ and $X \leq 1/2D$	3																											
$\Phi > 0.25$ and $X > 1/2D$	0																											

Other Inspection standard reference Bolymin standard.

## 11. Reliability

### ■ Content of Reliability Test

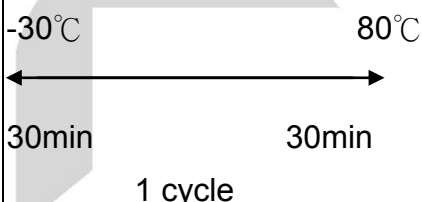
Environmental Test				
No	Test Item	Content of Test	Test Condition	Applicable Standard
1	High Temperature storage	Endurance test applying the high storage temperature for a long time.	80°C 96 hrs	—
2	Low Temperature storage	Endurance test applying the high storage temperature for a long time.	-30°C 96 hrs	—
3	High Temperature Operation	Endurance test applying the electric stress (Voltage & Current) and the thermal stress to the element for a long time.	70°C 96 hrs	—
4	Low Temperature Operation	Endurance test applying the electric stress under low temperature for a long time.	-20°C 96 hrs	—
5	Humidity Test	Endurance test applying the high humidity storage for a long time.	40°C, 90%RH 96hrs	—
6	Temperature cycle (Non-operation)	 <p>Endurance test applying the low and high temperature cycle.</p>	-30°C/80°C 10 cycles	—
7	Vibration test	Endurance test applying the vibration during transportation and using.	Total Fixed Amplitude: 1.5mm Vibration Frequency : 10~55Hz One cycle 60 seconds to 3 direction of X,Y,Z for each 15minutes	—

※Assess after placing at normal temperature and humidity for 4 hour ◦ No abnormalities in functions and appearance ◦





## 12-2 PCF2116CU controller data

### 12.2-1 function description

The address counter (AC) assigns addresses to both DDRAM and CGRAM

#### Display Data RAM (DDRAM)

This DDRAM is used to store the display data represented in 8-bit character codes. Its extended capacity is 80x8 bits or 80 characters. Below figure is the relationship between DDRAM addresses and positions on the liquid crystal display.

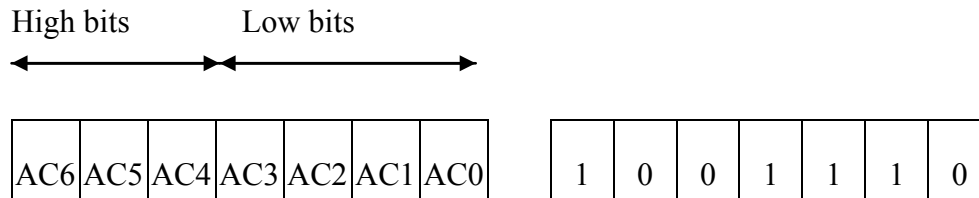

#### DDRAM Address

#### Display position DDRAM address

1	2	3	4	5	6	7	8	9	10	11	12	13	14	15	16	17	18	19	20
00	01	02	03	04	05	06	07	08	09	0A	0B	0C	0D	0E	0F	10	11	12	13
20	21	22	23	24	25	26	27	28	29	2A	2B	2C	2D	2E	2F	30	31	32	33
40	41	42	43	44	45	46	47	48	49	4A	4B	4C	4D	4E	4F	50	51	52	53
60	61	62	63	64	65	66	67	68	69	6A	6B	6C	6D	6E	6F	70	71	72	73

Example: 4-Line by 20-Character Display

## Relationship between CGRAM Addresses, Character Codes (DDRAM) and Character Patterns (CGRAM Data)

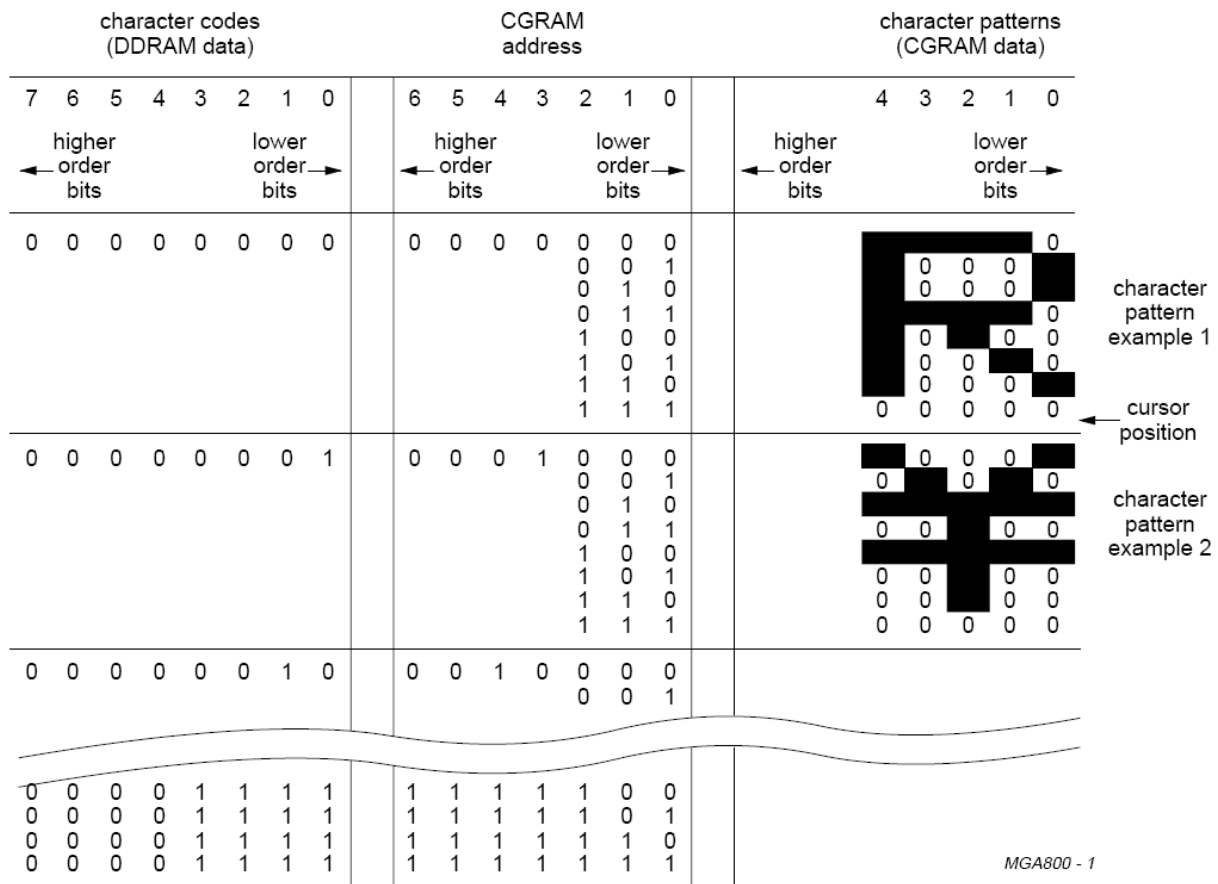

### Common bit identities

BIT	0	1
I/D	decrement	increment
S	display freeze	display shift
D	display off	display on
C	cursor off	cursor on
B	character at cursor position does not blink	character at cursor position blinks
S/C	cursor move	display shift
R/L	left shift	right shift
DL	4 bits	8 bits
G	voltage generator: $V_{LCD} = V_0$	voltage generator; $V_{LCD} = V_0 - 0.8V_{DD}$
N, (M = 0)		
PCF2116x	1 line × 24 characters; MUX 1 : 16	2 lines × 24 characters; MUX 1 : 32
PCF2114x	2 line × 12 characters; MUX 1 : 16	2 lines × 24 characters; MUX 1 : 32
N, (M = 1)	reserved	4 lines × 12 characters; MUX 1 : 32
BF	end of internal operation	internal operation in progress
Co	last control byte, only data bytes to follow	next two bytes are a data byte and another control byte

## 12.2-2 C.G ROM table

Code E: English

upper 4 bits lower 4 bits	0000	0001	0010	0011	0100	0101	0110	0111	1000	1001	1010	1011	1100	1101	1110	1111
xxxx 0000	CG RAM 1	1	2	3	4	5	6	7	8	9	0	1	2	3	4	5
xxxx 0001	2	3	4	5	6	7	8	9	0	1	2	3	4	5	6	7
xxxx 0010	3	4	5	6	7	8	9	0	1	2	3	4	5	6	7	8
xxxx 0011	4	5	6	7	8	9	0	1	2	3	4	5	6	7	8	9
xxxx 0100	5	6	7	8	9	0	1	2	3	4	5	6	7	8	9	0
xxxx 0101	6	7	8	9	0	1	2	3	4	5	6	7	8	9	0	1
xxxx 0110	7	8	9	0	1	2	3	4	5	6	7	8	9	0	1	2
xxxx 0111	8	9	0	1	2	3	4	5	6	7	8	9	0	1	2	3
xxxx 1000	9	0	1	2	3	4	5	6	7	8	9	0	1	2	3	4
xxxx 1001	10	1	2	3	4	5	6	7	8	9	0	1	2	3	4	5
xxxx 1010	11	2	3	4	5	6	7	8	9	0	1	2	3	4	5	6
xxxx 1011	12	3	4	5	6	7	8	9	0	1	2	3	4	5	6	7
xxxx 1100	13	4	5	6	7	8	9	0	1	2	3	4	5	6	7	8
xxxx 1101	14	5	6	7	8	9	0	1	2	3	4	5	6	7	8	9
xxxx 1110	15	6	7	8	9	0	1	2	3	4	5	6	7	8	9	0
xxxx 1111	16	7	8	9	0	1	2	3	4	5	6	7	8	9	0	1

### 12.2-3 Instruction table

INSTRUCTION	RS	R/W	DB7	DB6	DB5	DB4	DB3	DB2	DB1	DB0	DESCRIPTION	REQUIRED CLOCK CYCLES <sup>(2)</sup>
NOP	0	0	0	0	0	0	0	0	0	0	No operation.	0
Clear display	0	0	0	0	0	0	0	0	0	1	Clears entire display and sets DDRAM address 0 in Address Counter.	165
Return Home	0	0	0	0	0	0	0	0	1	0	Sets DDRAM address 0 in Address Counter. Also returns shifted display to original position. DDRAM contents remain unchanged.	3
Entry mode set	0	0	0	0	0	0	0	1	I/D	S	Sets cursor move direction and specifies shift of display. These operations are performed during data write and read.	3
Display control	0	0	0	0	0	0	1	D	C	B	Sets entire display on/off (D), cursor on/off (C) and blink of cursor position character (B).	3
Cursor/display shift	0	0	0	0	0	1	S/C	R/L	0	0	Moves cursor and shifts display without changing DDRAM contents.	3
Function set	0	0	0	0	1	DL	N	M	G	0	Sets interface data length (DL), number of display lines (N, M) and voltage generator control (G).	3
Set CGRAM address	0	0	0	1	A <sub>CG</sub>					Sets CGRAM address.	3	
Set DDRAM address	0	0	1	A <sub>DD</sub>					Sets DDRAM address.	3		
Read busy flag and address	0	1	BF	A <sub>C</sub>					Reads Busy Flag (BF) indicating internal operation is being performed and reads Address Counter contents.	0		
Read data	1	1	read data					Reads data from CGRAM or DDRAM.	3			
Write data	1	0	write data					Writes data to CGRAM or DDRAM.	3			

#### Notes

1. In the I<sup>2</sup>C-bus mode the DL bit is don't care. 8-bit mode is assumed.

In the I<sup>2</sup>C-bus mode a control byte is required when RS or R/W is changed; control byte: Co, RS, R/W, 0, 0, 0, 0, 0; command byte: DB7 to DB0.

2. Example:  $f_{osc} = 150 \text{ kHz}$ ,  $T_{cy} = \frac{1}{f} = 6.67 \mu\text{s}$ ; 3 cycles = 20  $\mu\text{s}$ , 165 cycles = 1.1 ms.

## 12.2-4 Timing characteristics

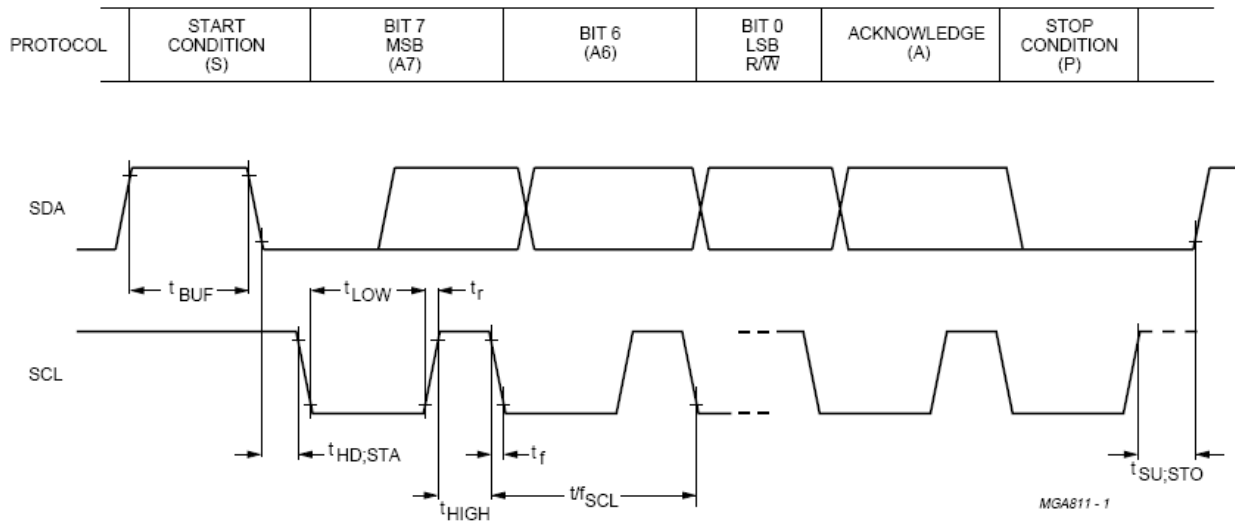

$f_{SCL}$	SCL clock frequency	–	–	100	kHz
$t_{SW}$	tolerable spike width on bus	–	–	100	ns
$t_{BUF}$	bus free time	4.7	–	–	$\mu$ s
$t_{SU,STA}$	set-up time for a repeated START condition	4.7	–	–	$\mu$ s
$t_{HD,STA}$	START condition hold time	4	–	–	$\mu$ s
$t_{LOW}$	SCL LOW time	4.7	–	–	$\mu$ s
$t_{HIGH}$	SCL HIGH time	4	–	–	$\mu$ s
$t_r$	SCL and SDA rise time	–	–	1	$\mu$ s
$t_f$	SCL and SDA fall time	–	–	0.3	$\mu$ s
$t_{SU,DAT}$	data set-up time	250	–	–	ns
$t_{HD,DAT}$	data hold time	0	–	–	ns
$t_{SU,STO}$	set-up time for STOP condition	4	–	–	$\mu$ s

## Bit transfer

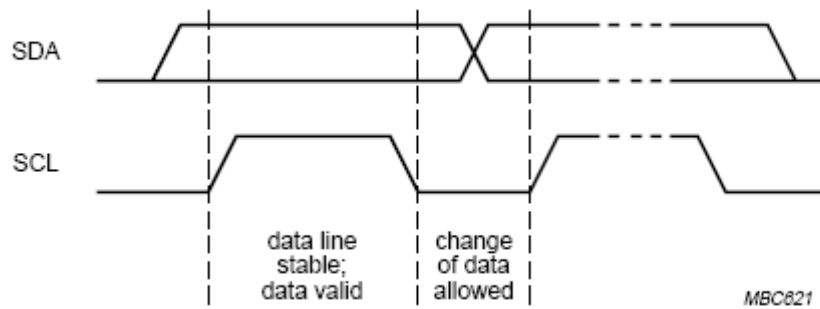

## Definition of START and STOP conditions

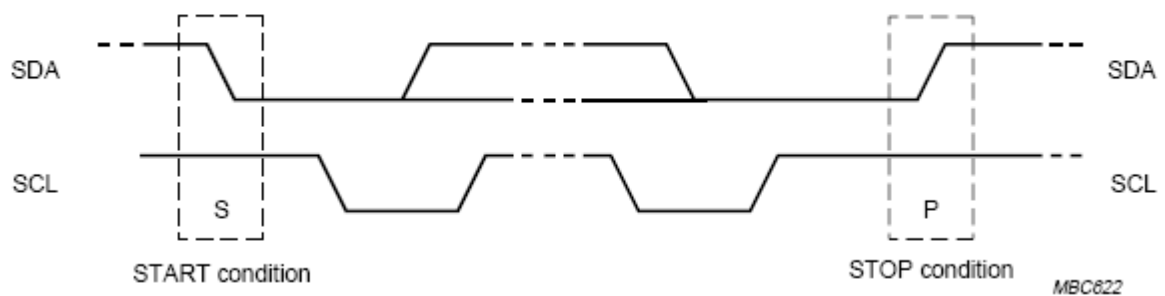

## System configuration

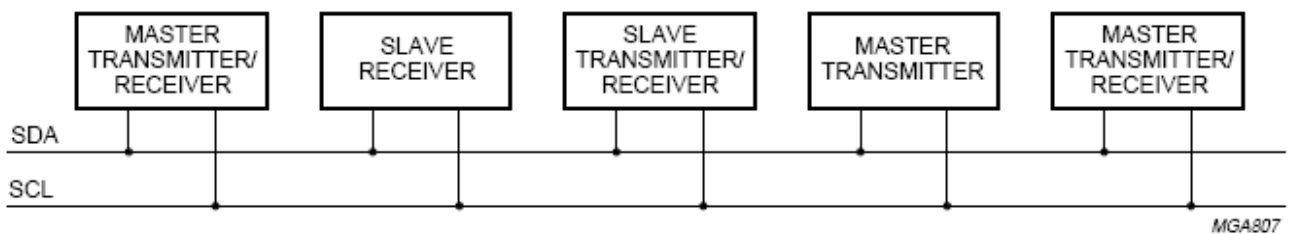

## Acknowledgement on the I2C-bus

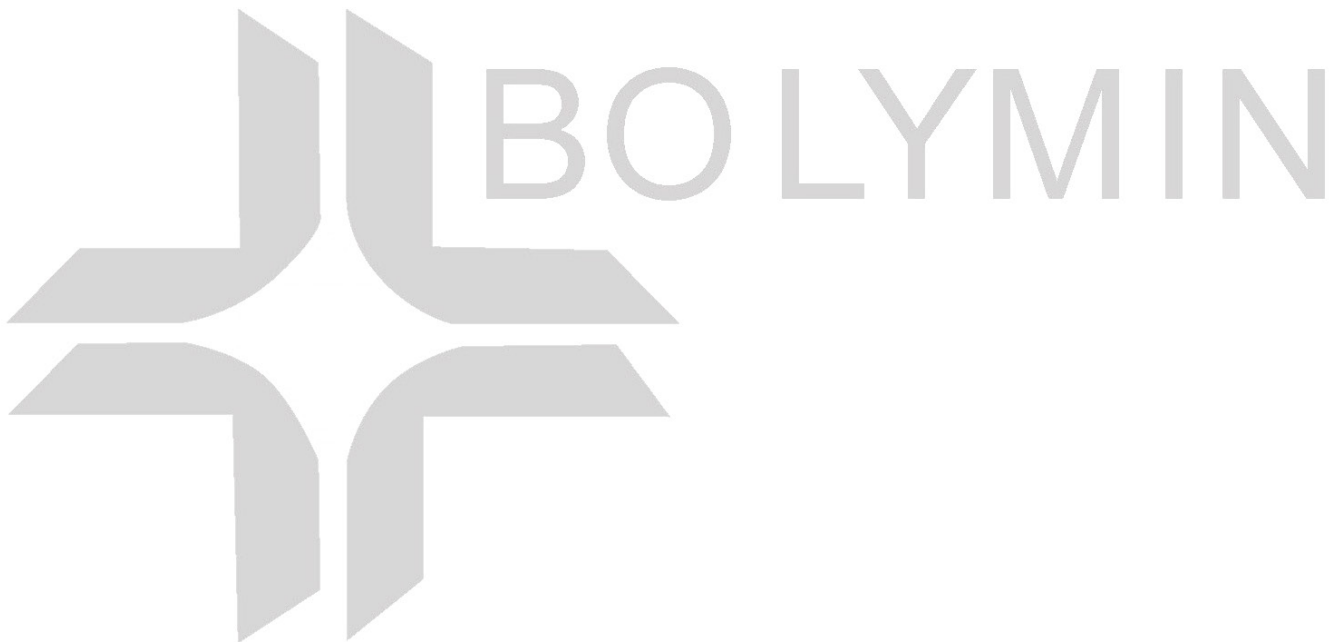
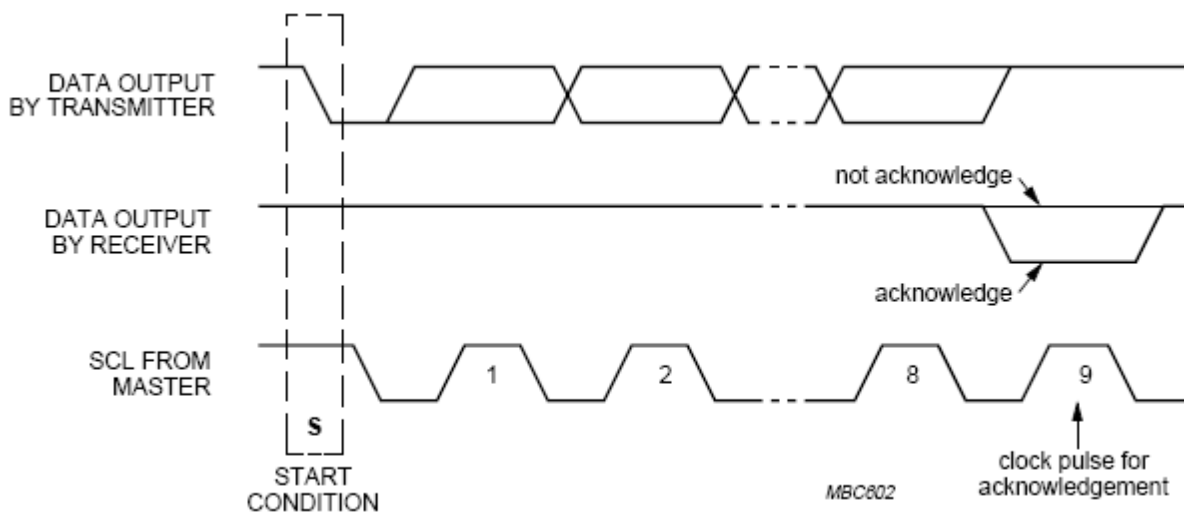



### 12.2-5 I2C address

Master transmits to slave receiver; WRITE mode.

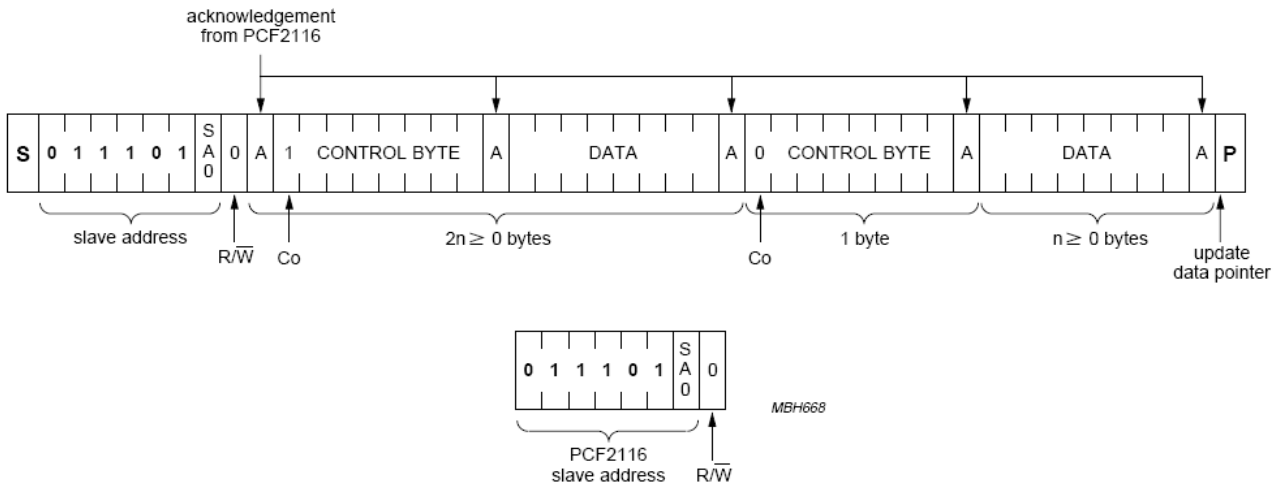

Master reads after setting word address; write word address, set RS/RW; READ data.

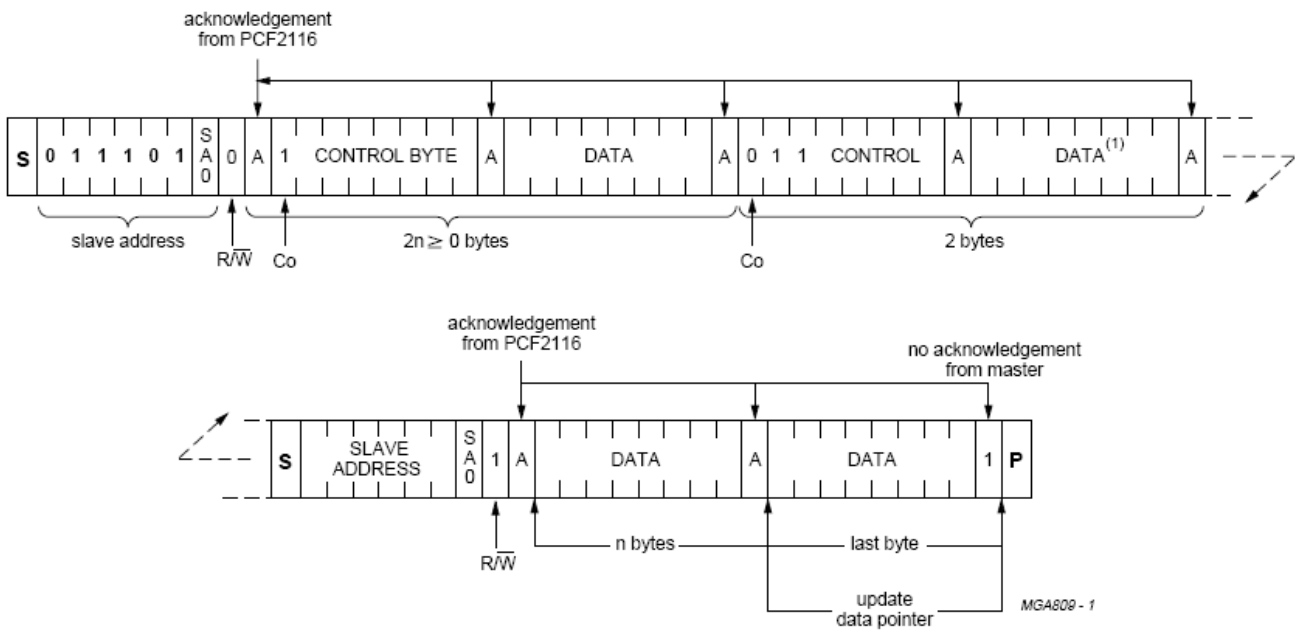

Master reads slave immediately after first byte; READ mode (RS previously defined).

